

## **SMART *WIMAX* INDOOR CPE ANTENNAS**

By  
David Shani  
VP of International Marketing & Sales  
MTI Wireless Edge Ltd.

## Table of Contents

Introduction.....	3
Smart CPE Antenna Systems.....	3
MTI Smart WIMAX CPE.....	3
Smart Array Cost Tradeoff .....	5
3x120°, 4x90° and 6x60° Arrays, .....	5
Summary and Conclusions .....	5
About MTI Wireless Edge Ltd .....	6

This document contains information that is protected by copyright. All rights are reserved. No part of this document may be photocopied, reproduced or translated into another language without the prior written consent of Mti Wireless Edge Ltd. The information in this document is subject to change without notice. Mti Wireless Edge makes no warranty of any kind with regard to this printed material, including, but not limited to the implied warranties of merchantability and fitness for a particular purpose. Mti Wireless Edge shall not be liable for errors contained herein or for incidental or consequential damages in connection with the furnishing, performance, or use of this material. Brand or product names are trademarks of their respective companies or organizations.

Copyright © 2005, by MTI Wireless Edge Ltd.  
11 Hamelacha St. Afek Industrial Park. Rosh Ha'ayin 48091, Israel.  
Tel: 972-3-9008900. Fax: 972-3-9008901  
<http://www.mtiwe.com/>

## Introduction

An important goal of WiMAX next generation Smart CPE Antennas is the ability to offer higher performance by delivering higher gain, increased rejection of multi-path interference and ease of installation. This white paper examines the need for Smart WIMAX indoor CPE antennas and details the specific parameters of Smart Antenna products offered by MTI Wireless Edge.

Smart CPE antennas are a powerful tool offering improved performance, self-install ability, reliable non-line of sight [NLOS] operation and compact size.

Smart antenna technology, delivering 360° coverage, separated high gain beam [improved C/N] and interference suppression [improved C/I], can significantly increase the performance of wireless systems.

The need for Smart antenna solutions increase with the growth of interference, propagation complexity and indoor performance.

The benefit of a more focused and efficient use of a system's power can be significant.

---

## Smart CPE Antenna Systems

A smart antenna system is one that has circuit elements associated with its radiating elements such that the antenna properties are controlled by the received signal

A smart CPE antenna can be made up of a combination of from 2 to as many antenna elements as are needed to maximize the required antenna performance.

There is however a trade off, a greater the number of antenna elements [more sectors] results in:

1. Narrower the instantaneous azimuth beamwidth
2. Higher gain [C/N]
3. Larger the physical dimensions
4. Better selectivity
5. less interference [C/I]

Practically Smart CPE Antenna arrays are made up of from 4 to 8 antenna elements

An additional consideration is that given the same Azimuth beamwidth and the same number of elements an increase in the length of the antenna elements will deliver increased gain.

---

## MTI Smart WIMAX CPE

The MTI smart WIMAX indoor CPE is a compact and easy to integrate, switch selectable antenna array specifically designed to meet the needs of the WIMAX market. The antenna which includes the solid state RF switch is designed to be either integrated as part of the radio, or, supplied as a separate unit to be added on to the radio by the end user.

The antenna provides full 360 deg coverage by multi directional high gain beams. The high gain directional beams provide better RF link budgets with the base station and reduce side lobes interference.

The smart CPE antenna can include 4 to 8 elements with the integral

---

solid state RF switch controlling the active sector.

The higher the number of beams the higher the gain provided by each beam and the narrower the beam width.

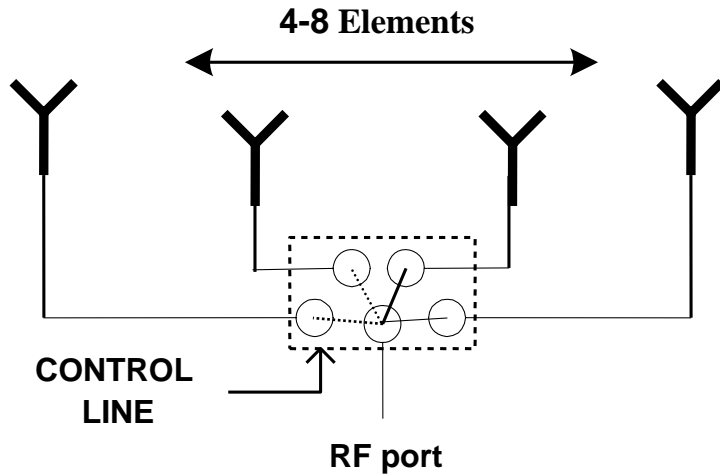

Figure 1. Schematic Diagram of a 4 Element Unit

MTI Smart CPE antenna arrays are currently offered in variety of frequencies bands and azimuth beam widths delivering element gain between 6 and 9.5 dBi per sector dependant on the frequencies beam width:

**Frequencies bands:**

3.3-3.5, 3.4-3.6, 3.5-3.8, 4.9-5.03, 5.15-5.35, 5.47-5.825 GHz

**Beam widths delivering 360° coverage:**

- 4 elements spanning 90° per element
- 6 elements of 60° per element
- 8 elements of 45° per element.

**Smart WiMAX CPE MTI antennas available for 3.5 GHz**

F (GHz)	Azimuth B.W.	Peak Gain (dBi)	Elevation B.W.	Dimensions (HxD)
3.3-3.5	4x90°	7±1	45° (typ)	115x55mm (max)
3.4-3.6	4x90°	7.5±1	40° (typ)	115x55mm (max)
3.5-3.7	4x90°	7.5±1	35° (typ)	115x55mm (max)
3.6-3.8	4x90°	7.5±1	35° (typ)	115x55mm (max)
3.4-3.6	4x90°	9.5±1	15° (typ)	170x60mm (max)

## Smart Array Cost Tradeoff

The number of beams, gain, and beam width is a tradeoff of the price.

The higher the number of antennas elements [beams] making up the array the higher the gain - the larger the size and higher the price.

Lower gain results in reduced size and price.

---

## 3x120°, 4x90° and 6x60° Arrays,

One of 4 elements spanning 90° per segment,

One of 6 elements spanning 60° per segment,

One of 8 elements spanning 45° per segment.

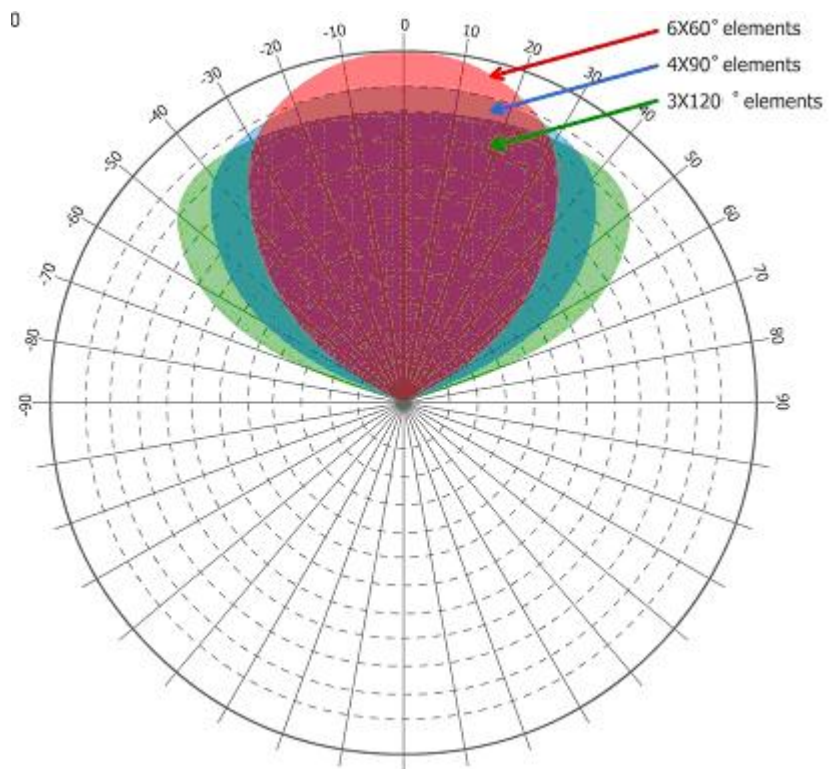

Figure 2. 3, 4 and 6 Elements Array

---

## Summary and Conclusions

MTI Wireless Edge provides a large selection of self-installed smart antennas for WiMAX next generation CPE improving the system performance and network coverage. It also allows to choose the most cost-effective antenna solution for the CPE and to improve the Return On Investment [ROI] of the WiMAX network.

---

## About MTI Wireless Edge Ltd

MTI Wireless Edge is the world leader in the development, production and marketing of high quality, low cost, flat panel antennas for Fixed Wireless and RFID applications. MTI has more than 30 years experience in supplying antennas for both military and commercial applications from 100 KHz to 40 GHz. MTI flat panel antenna range for FBWA includes both base station and subscriber antennas for various broad and narrow band fixed wireless applications in Point-to-Point (PTP) and Point-to-Multipoint (PMP) schemes such in both licensed and unlicensed bands. MTI Military products include a wide range of broadband, tactical and specialized communications antennas, antenna systems and DF arrays installed on numerous airborne, ground and naval, including submarine, platforms worldwide. MTI's ISO 9001 and ISO 14001 certified development and production plant, based in Israel, produces small, low profile antennas with superior performance, and gain. In house test facilities include antenna test ranges, varying in length from 8 meters to 300 meters. We Are Taking Wireless Technology To The Edge. Visit us at [www.mtiwe.com](http://www.mtiwe.com)

**Contact: MTI Wireless Edge Ltd**

**David Shani**

**VP Int'l Sales & Marketing**

**MTI Wireless Edge Ltd**

Tel: +972 3 9008900

E-mail: [david\\_s@mti-group.co.il](mailto:david_s@mti-group.co.il)